

SLZ 1200 S

Cycle control:

Heidenhain MANUALplus 620 or Siemens 840D SolutionLine with user interface Operate with manual functions

Specifications and performance

Specifications

SLZ 1200 S	Unit	Value
Swing over bed	mm	1.250-1.600 (Option)
Swing over cross slide	mm	850-1.200
Bed width	mm	900
Spindle head in accordance with DIN 55027	size	15
Spindle bore \varnothing	mm	110
Spindle \varnothing in the front bearing	mm	240
Tailstock quill \varnothing	mm	220
Tailstock stroke	mm	315
Tailstock Morse taper	-	center installed rigidly
Center distance	m	3,0-20,0

Performance

SLZ 1200 S	Unit	Value
Main drive	KW	70
Speed range	1/min	1-710

Dimensions

Length	mm	5.500 +Center Distance
Width	mm	3.450
Height	mm	2.780

Please note:

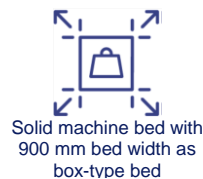
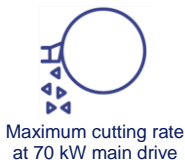

Plus control cabinet of approx. 500 x 2000 mm

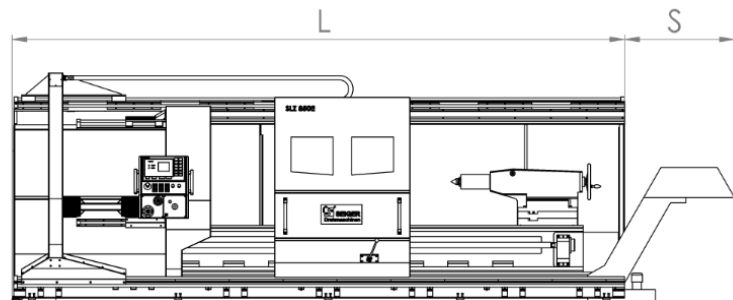
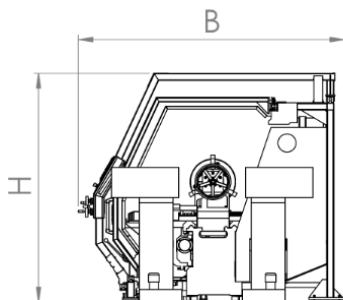

Technical changes and errors excepted